

## CHAIN FILING CHART

WINDSOR	SPECIFICATIONS FILING			FILING TOOLS AND PART NUMBERS		
PART NUMBER	TOP-PLATE CUTTING ANGLE	TOP-PLATE FILING ANGLE	FILE-GUIDE ANGLE	DEPTH GAUGE SETTING	FILE DIAMETER	FILE PART NUMBERS (1-PACK OR 3-PACK)
<b>1/4"-PITCH CHAINS</b>						
50K	60	30	10	.025"	5/32"	168-8-4.0-1PW, 168-8-4.0-3PW
<b>.325"-PITCH CHAINS</b>						
50, 58, 63J, JG	60	30	90	.025"	3/16"	168-8-4.8-1PW, 168-8-4.8-3PW
50, 58, 63JL, JLG, JLX	60	30	10	.025"	3/16"	168-8-4.8-1PW, 168-8-4.8-3PW
<b>3/8"-PITCH CHAINS</b>						
43RG	50	30	90	.025"	11/64"	168-8-4.5-1PW
50R, RG	60	30	90	.025"	5/32"	168-8-4.0-1PW, 168-8-4.0-3PW
50, 58, 63A, AG	60	30	90	.025"	7/32"	168-8-5.5-1PW, 168-8-5.5-3PW
50, 58, 63APL, APLG, APLX	60	25	10	.025"	7/32"	168-8-5.5-1PW, 168-8-5.5-3PW
<b>.404"-PITCH CHAINS</b>						
63B	60	35	10	.028"	7/32"	168-8-5.5-1PW, 168-8-5.5-3PW
63BL	60	25	10	.025"	7/32"	168-8-5.5-1PW, 168-8-5.5-3PW
63BR	60	5	10	.030"	7/32"	168-8-5.5-1PW, 168-8-5.5-3PW
HC, 2HC	60	30	10	.050"	7/32"	168-8-5.5-1PW, 168-8-5.5-3PW
<b>3/4"-PITCH CHAINS</b>						
3HC	60	35	90	.060"	5/16"	FILES ARE NOT AVAILABLE FOR THIS CHAIN

## GRINDING INSTRUCTIONS FOR HARVESTER CHAINS

### GRINDER SETTING

Top Plate Grinding Angle: 30°

Top Plate Cutting Angle: 60°

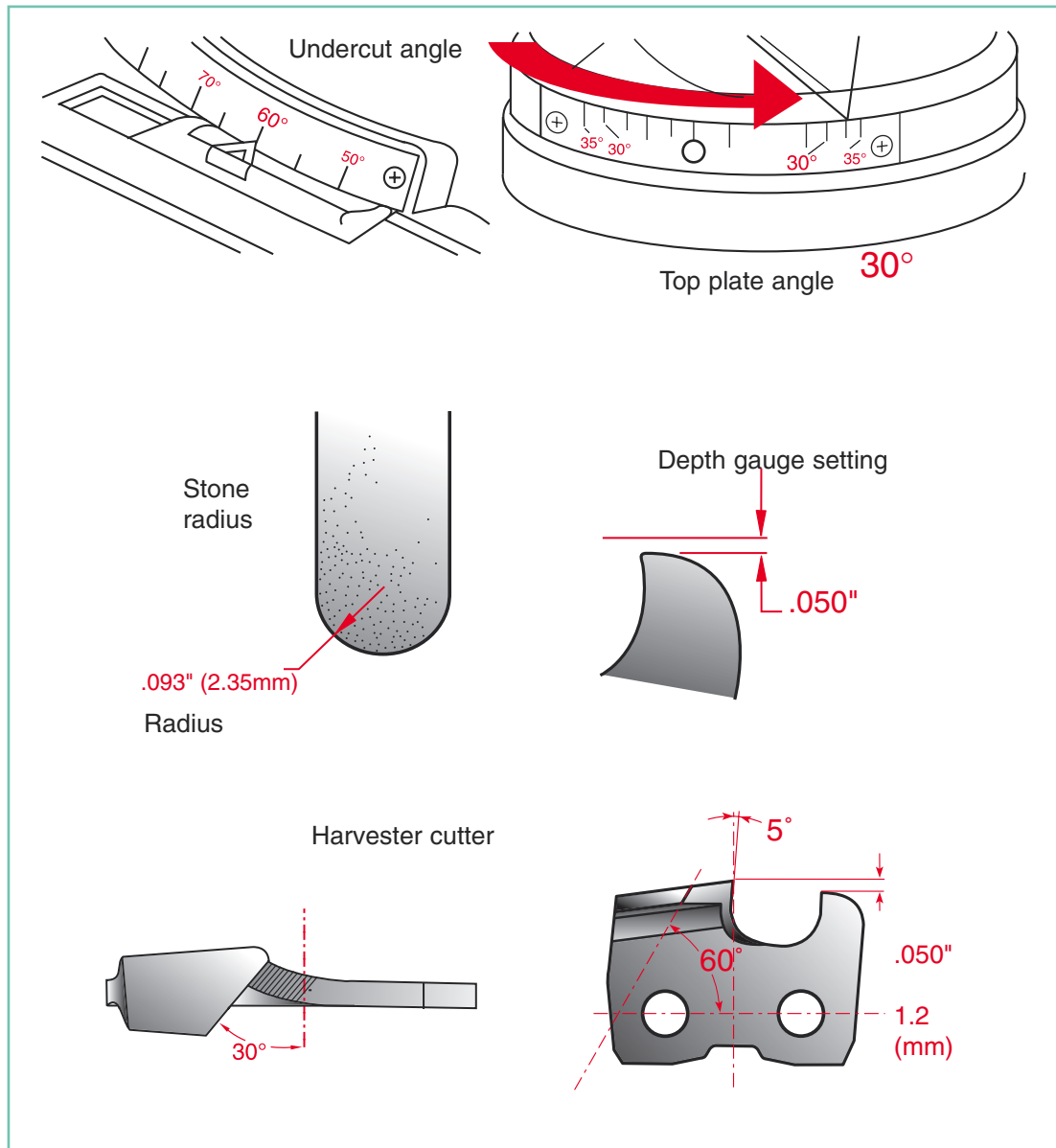

### NOTE!

- Windsor Forestry Tools harvester chains have been developed solely for use with mechanised harvesting machines. If they are used in combination with normal power chainsaws, kickbacks may lead to severe injuries.